

SHELL AND TUBE HEAT EXCHANGERS

Removable Bundle Design

(Single Wall, Double Wall and Hi-Temperature Units)



Latest Update: 01/08/2025

DISCLAIMER

The information contained in this document is subject to change without notice from Diversified Heat Transfer, Inc. (DHT). DHT makes no warranty of any kind in respect to this material, including but not limited to, implied warranties of merchantability and fitness for a particular application. DHT is not liable for errors appearing in this document, nor for incidental or consequential damages occurring in connection with the furnishing, performance, or use of these materials.

Table of Contents

- Introduction and Safety** 2
 - Introduction 2
 - Safety 2
 - Safety terminology and symbols 2
 - User Safety 3
 - Product warranty 4
 - Warranty Claim..... 4

- Product Description** 5
 - General description 5

- Storage and Installation**..... 6
 - Storage 6
 - Installation..... 6

- Operation**..... 7
 - Startup and shutdown procedures 7

- Maintenance** 8

- REPLACEMENT PARTS**
 - Replacement Parts..... 10

Introduction and Safety

INTRODUCTION

The purpose of this manual is to provide necessary information for:

- Installation
- Operation
- Maintenance



CAUTION:

Read this manual carefully before installing and using the product. Improper use of the product can cause personal injury and damages to property and may void the warranty.

NOTICE:

Save this manual for future reference, and keep it readily available at the location of the unit.

SAFETY



WARNING:

- The operator must be aware of safety precautions to prevent physical injury.
 - Operating, installing, or maintaining the unit in any way that is not covered in this manual could cause death, serious injury, or damage to the equipment. This includes any modification to the equipment or use of parts not provided by DHT. If there is a question regarding the intended use of the equipment, please contact a DHT representative before proceeding.
 - Do not change the service application without the approval of an authorized DHT representative.
-



CAUTION:

You must observe the instructions contained in this manual. Failure to do so could result in physical injury, damage, or delays.

Terminology and symbols

It is extremely important that you read, understand, and follow the safety messages and regulations carefully before handling the product. They are published to help prevent these hazards:

- Personal accidents and health problems
- Damage to the product
- Product malfunction

Hazard levels



DANGER:

A hazardous situation which, if not, avoided, will result in death or serious injury



WARNING:

A hazardous situation which, if not, avoided, could result in death or serious injury



CAUTION:

A hazardous situation which, if not, avoided, could result in minor or moderate injury

NOTICE:

- A potential situation which, if not avoided, could result in undesirable conditions
 - A practice not related to personal injury
-

Hazard categories

Hazard categories can either fall under hazard levels or let specific symbols replace the ordinary hazard level symbols.

These are examples of other categories that can occur. They fall under the ordinary hazard levels and may use complementing symbols:

- Crush hazard
- Cutting hazard
- Arc flash hazard

USER SAFETY

General safety rules

Applicable general safety rules:

- Always keep the work area clean.
- Pay attention to the risks presented by gas and vapors in work area.
- Avoid all electrical dangers and pay attention to the risks of electric shock or arc flash hazards.
- Always bear in mind the risk of drowning, electrical accidents, and burn injuries.



This product can expose you to Lead, which is known to the state of California to cause cancer and birth defects and other reproductive harm. For more info go to: www.P65Warnings.ca.gov

Safety equipment

Use safety equipment according to the company regulations. Use this safety equipment within the work area:

- Hard hat
- Safety goggles, preferably with side shields
- Protective shoes
- Protective gloves
- Gas mask
- Hearing protection
- First-aid kit
- Safety devices

NOTICE:

Never operate a unit unless safety devices are installed. Also see specific information about safety devices in other chapters of this manual.

PRODUCT WARRANTY

Coverage

DHT undertakes to remedy defects in products from DHT under these conditions:

- The faults are due to defects in design, materials, or workmanship.
- The faults are reported to a local sales and service representative within the warranty period.
- The product is used only under the conditions that are described in this manual.
- Genuine DHT parts are used.

Limitations

Warranty does not cover defects caused by:

- Deficient maintenance
- Improper installation
- Modifications or changes to the product and installation that are made without consulting a DHT authorized representative
- Incorrectly executed repair work
- Normal wear and tear

DHT assumes no liability for the following situations:

- Bodily injury
- Material damages
- Economic losses

Warranty claim

DHT products are high quality products with expected reliable operation and long life. However, should the need for a warranty claim arise, contact your local sales representative or the manufacturer.

Product Description

GENERAL DESCRIPTION

DHT Series heat exchangers are U-Tube design with removable heads and bundles. Tubing is 3/4" OD and is available in a variety of materials.

STORAGE

NOTE: If the heat exchanger cannot be installed and put into operation immediately upon receipt at the jobsite, certain precautions are necessary to prevent deterioration during storage. Responsibility for integrity of the heat exchangers must be assumed by the user. DHT will not be responsible for damage, corrosion or other deterioration of heat exchanger equipment during transit and storage. Good storage practices are important, considering the high costs of repair or replacement, and the possible delays for items which require long lead times for manufacture. The following suggested practices are provided solely as a convenience to the user, who shall make his own decision on whether to use all or any of them.

1. On receipt of the heat exchanger, inspect for shipping damage to all protective covers. If damage is evident, inspect for possible contamination and replace protective covers as required. If damage is extensive, notify the carrier immediately.
2. If the heat exchanger is not to be placed in immediate service, take precautions to prevent rusting or contamination.
3. Heat exchangers for oil service, made of ferrous materials, may be pressure tested with oil at the factory. However, the residual oil coating on the inside surfaces of the exchanger does not preclude the possibility of rust formation. Upon receipt, fill these exchangers with appropriate oil or coat them with a corrosion prevention compound for storage.
4. The choice of preservation of interior surfaces during storage for other service applications depends upon your system requirements and economics. Only when included in the original purchase order specifications will specific preservation be incorporated prior to shipment from the factory.
5. Remove any accumulations of dirt, water, ice or snow and wipe dry before moving exchangers into indoor storage. If unit was not filled with oil or other preservative, open drain plugs to remove any accumulated moisture, then reseal. Accumulation of moisture usually indicates rusting has already started and remedial action should be taken.
6. Store under cover in a heated area, if possible. The ideal storage environment for heat exchangers and accessories is indoors, above grade, in a dry, low humidity atmosphere which is sealed to prevent entry of blowing dust, rain or snow. Maintain temperatures between 70°F and 105°F (wide temperature swings may cause condensation and "sweating" of steel parts). Cover windows to prevent temperature variations caused by sunlight. Provide thermometers and humidity indicators at several points, and maintain atmosphere at 40% relative humidity or lower.
7. In tropical climates, it may be necessary to use trays of renewable desiccant (such as silica gel), or portable dehumidifiers, to remove moisture from the air in the storage enclosure. Thermostatically controlled portable heaters (vented to outdoors) may be required to maintain even air temperatures inside the enclosure.
8. Inspect heat exchangers and accessories frequently while they are in storage.
9. If paint deterioration begins, as evidenced by discoloration or light rusting, consider touch-up or repainting. If the unit is painted with our standard shop enamel, areas of light rust may be wire brushed and touched-up with any good quality air-drying synthetic enamel. Units painted with special paints (when specified on customers' orders) may require special techniques for touch-up or repair.

Obtain specific information from the paint manufacturer. Painted steel units should never be permitted to rust or deteriorate to a point where their strength will be impaired. A light surface rust, on steel units which can be repainted after installation, will not generally cause any harm. (See Items 3 and 4 for internal surface preservation.)

10. If the internal preservation (Items 3 and 4) appears inadequate during storage, consider additional corrosion prevention measures and more frequent inspections. Interiors coated with rust preventive should be restored to good condition and recoated promptly if signs of rust occur.

INSTALLATION

1. Provide sufficient clearance at the head of the unit to permit removal of tube bundle from shell.
2. Provide valves and by-passes in the piping so that both the shell and tube bundle may be by-passed to permit isolation of the unit for inspection or repairs.
3. Provide thermometer wells and pressure gauge connections in all piping to and from the unit and located as near the unit as possible.
4. Provide convenient means for frequently cleaning the unit as suggested under "MAINTENANCE."
5. Provide necessary air cocks for units so they can be purged to prevent or relieve vapor binding of either the tube bundle or the shell.
6. Foundations must be adequate so that exchangers will not settle and cause piping strains. Foundation bolts should be set to allow for setting inaccuracies. In concrete footings, pipe sleeves at least one size larger than bolt diameter slipped over the bolt and cast in place are best for this purpose, as they allow the bolt center to be adjusted after the foundation has set.

 **WARNING:** All system piping to the heat exchanger must be adequately supported. Failure to do so will result in excessive loads on the heat exchanger connections causing damage and/or leakage and potential injury to adjacent personnel.

 **WARNING:** When installing a Diamondback™ heat exchanger above a ceiling or workstation where personnel are present, it may be necessary to install a drip pan to collect any tell-tale drip due to internal tube failure. Failure to do so may result in damage to the ceiling and potential injury to personnel.

7. Loosen foundation bolts at one end of unit to allow free expansion of shells. Oval holes in foundation brackets are provided for this purpose.

 **CAUTION:** Provision must be made to isolate the heat exchanger from any external vibrations that cause tube failures within the heat exchanger. Result is internal leakage and mixing of the hot and cold media.

- Set exchangers level and square so that pipe connections may be made without forcing.

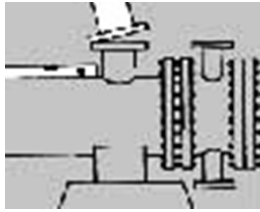

CAUTION: Provision must be made to isolate the heat exchanger from any external vibrations that cause tube failures within the heat exchanger. Result is internal leakage and mixing of the hot and cold media.

- Inspect all openings in exchanger for foreign material. Remove all wooden plugs and shipping pads just before installing. Do not expose units to the elements with pads or other covers removed from nozzles or other openings since rain water may enter the unit and cause severe damage due to freezing.
- Be sure the entire system is clean before starting operation to prevent plugging of tubes with sand or refuse. The use of strainers in settling tanks in pipe lines leading to the unit is recommended.
- Drain connections should not be piped to a common closed manifold.
- Steam hammer can cause serious damage to the tubes of any heat exchanger. A careful consideration of the following points before an installation is made can prevent costly repairs which may be caused by steam hammer.
 - A vacuum breaker and/or vent, should be used in accordance with the type of steam system installed.
 - The proper trap for the steam system installed should be used.
 - The trap and condensate return line to the trap should be properly sized for the total capacity of the converter.
 - The trap should be sized for the pressure at the trap, not the inlet pressure to the steam controller.
 - Condensate should be piped and pitched to a condensate receiver, condensate return pump or drain at an elevation below the heat exchanger.

CAUTION: During times of shutdown, volumetric expansion can occur. We recommend the installation of a properly sized relief valve on both sides of the heat exchanger. Failure to do so can cause damage to the heat exchanger.

OPERATION

- When placing a unit in operation, open the vent connections and start to circulate the cold medium only. Be sure that the passages in the exchanger are entirely filled with cold fluids before closing the vents. The hot medium should then be introduced gradually until all passages are filled with liquid, close vents and slowly bring the unit up to temperature.

- Start operation gradually. Do not admit hot fluid to the unit suddenly when empty or cold. Do not shock unit with cold fluid when unit is hot.

CAUTION: Fluids must be gradually introduced to the unit. Failure to do so can cause damage to the heat exchanger.

- Do not operate equipment under conditions in excess of those specified on nameplate.

WARNING: Failure to operate the heat exchanger within the design pressure and temperature on the nameplate may result in damage to the heat exchanger and potential injury to adjacent personnel.

CAUTION: Fluid and/or steam velocities in excess of design operating conditions on either the shell or tube side of the heat exchanger can cause damaging tube erosion and/or vibrations. Result is internal leakage and mixing of the hot and cold media. Proper setting of system controls is required.

- In all installations, there should be no pulsation of fluids since this causes vibration and strain with resulting leaks.
- Retighten bolting on all gasketed joints after the heat exchanger has reached operation temperatures to prevent leaks and gasket failures. Retightening should be done uniformly and in a diametrically staggered pattern as illustrated in "MAINTENANCE".
- On high pressure and high temperature applications where an "HTWU/DHTWU" heat exchanger is used or any application where spiral wound gaskets are required, it is recommended that the gasketed joints of the heat exchanger be retightened to the required torque (see "MAINTENANCE") after 24 hours at operating pressures and temperatures to compensate for any relaxation or creep that may have occurred.
- In shutting down, flow of hot medium should be shut off first. If it is necessary to stop circulation of cooling medium the circulation of hot medium should also be stopped by bypassing or otherwise.
- Drain all fluids when shutting down to eliminate the possibility of freezing and corrosion. To guard against water hammer, condensate should be drained from steam heaters and similar apparatus both when starting up and when shutting down.
- Heat exchangers that are out of service for extended periods of time should be protected against corrosion as described in the storage requirements for new heat exchangers.

Heat exchangers that are out of service for short periods and use water as the flowing medium should be thoroughly drained and blown dry with warm air, if possible. If this is not practical, the water should be circulated through the heat exchanger on a daily basis to prevent stagnant water conditions that can ultimately cause corrosion.

MAINTENANCE

1. Do not open heads until all pressure is off equipment, the unit drained of all fluids, and the equipment surfaces cooled to ambient temperature.
2. Do not blow out heat exchangers with air when operating fluids are of a flammable or otherwise hazardous nature.

⚠WARNING: Proper precautions must be taken (special clothing, equipment, etc.) to protect personnel from injury due to escaping fluids or hot heat exchanger surfaces.

3. Provide convenient means for frequently cleaning heat exchangers as suggested below:
 - a. Circulating hot wash oil or light distillate through tubes or shell at good velocity will effectually remove sludge or other similar soft deposits.
 - b. Soft salt deposits may be washed out by circulating hot fresh water.
 - c. Some cleaning compounds on the market, such as "Oakite" may be used to advantage for removing sludge or coke, provided hot wash oil or water, as described above, does not give satisfactory results.
 - d. If the above methods are ineffective for removal of hard scale, a mechanical means may be used.

⚠WARNING: Care must be exercised when handling certain fluids. Follow manufacturers instructions. Use eye and skin protection. Wear a respirator when required.

4. Do not attempt to clean tubes by blowing steam through individual tubes. This overheats the tube and results in tube expansion strains and sometimes leaking tubes.
5. Frequently and at regular intervals, observe interior and exterior condition of all tubes and keep them clean. Frequency of cleaning should be according to scale build-up.

⚠CAUTION: Neglect in keeping all tubes clean may result in complete stoppage of flow through some tubes with consequent overheating of these tubes, resulting in severe expansion strains, leaking tube joints, and damage to the heat exchanger.

6. Exchangers subject to fouling or scaling should be cleaned periodically. A light sludge or scale coating on the tube greatly reduces its effectiveness. A marked increase in pressure drop and/or reduction in performance usually indicates cleaning is necessary, if the unit has been checked for air or vapor binding and this has been found not to be the cause. Since the difficulty of cleaning increases rapidly as the scale thickens or deposits
7. increase, the interval between cleanings should not be excessive. At times, it may be necessary to locate a ruptured tube or a leaking joint between the tubes and the tubesheet of a single wall heat exchanger. The following procedure is recommended.

- a. Following the procedures previously mentioned for front head removal, remove the head and replace it with a companion flange that mates with the shell body flange. Replace the nuts and bolts/studs.
- b. Pressurize the shellside of the heat exchanger with a cold fluid, preferably water.
- c. Observe all tube joints and tube ends for indication of test fluid leakage.
- d. To tighten a leaking tube joint, use a suitable parallel roller tube expander.

⚠CAUTION: When tightening leaking tube joints:

1. Do not roll tubes beyond the back face of the tubesheet. Maximum rolling depth should be the tubesheet thickness minus 1/8".
2. Do not re-roll tubes that are not leaking since this will thin the tube wall.

The result of either of the above conditions can lead to failure of the tube and a leaking bundle.

- e. If an emergency repair of a tube is required, use suitable tube plugs to seal off both ends of the U-bend tube. Some loss of performance will result until a new replacement tube bundle is obtained. Consult your local DHT Representative for proper replacement of the bundle.

⚠CAUTION: Field repair of Diamondback™ double wall heat exchangers is not recommended. Rerolling of the tube joints may result in the closing of the leak detector flow paths between the two tube walls preventing the heat exchanger from providing a positive indication of potential cross contamination.

8. Tube bundle removal:

- a. During bundle removal, the dead weight of bundle should never be supported on individual tubes. Rest the bundle on the tube sheet, support plates, or wood blocks cut to fit periphery of the bundle.
- b. Tube bundles may be raised using slings formed by bending light plates into a form and attaching lifting lugs to the ends of the sheets. Baffles can be easily bent and damaged if dragged over rough surfaces.

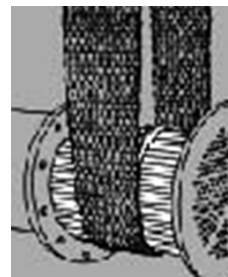

⚠CAUTION: When cleaning a tube bundle, tubes should not be hammered on with any metallic tool and, in case it is necessary to use scrapers, care should be exercised that the scraper is not sharp enough to cut the metal of the tubes.

9. Before reinserting the tube bundle into the shell or collar of a tank, place the ring/tank gasket over the end of the tube bundle and bring forward to the backside of the tubesheet.

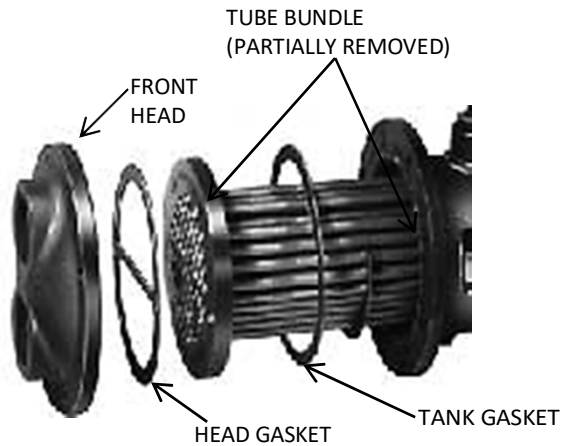

10. The tube bundle can be replaced using the tools and reverse procedure given for bundle removal.

11. When installing a Diamondback™ double-wall tube bundle, make sure the leak path drain hole in the spacer ring between the two tubesheets is in the lowest position of the tubesheet circle.

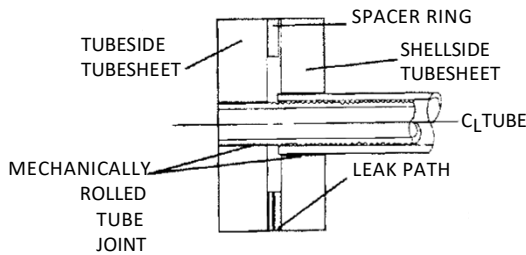

DOUBLE-WALL TUBE JOINT

12. When replacing the heads, use a torque wrench to tighten the bolts/studs and nuts. Use the following chart as a guide. All torque values apply to well lubricated nut bearing surfaces. All bolted joints should be tightened uniformly and in a diametrically staggered pattern as illustrated below:

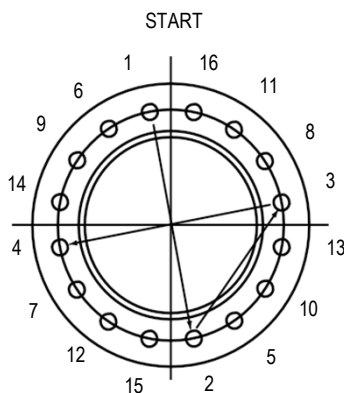

WARNING: It is extremely important to follow a proper tightening sequence. If it is not followed, the flanges can become cocked and a leak will result. When tightening flanges with spiral wound gaskets, if cocking occurs, the result can be deformation and non-repairable damage to the gaskets in addition to a resultant leak. Any gasket leak can result in potential injury to adjacent personnel.

COMPRESSED FIBER GASKETS			
Bolt Dia.	Recommended Torque ft-lbs	Torque Increment	Max. Torque
1/2"	40	5	60
5/8"	80	5	120

SPIRAL WOUND GASKETS			
Bolt/Stud Dia.	Recommended Torque ft-lbs	Torque Increment	Max. Torque
1/2"	40	5	60
5/8"	80	5	120
3/4"	120	5	200
7/8"	200	10	320
1"	300	10	490
1 1/8"	450	10	710
1 1/4"	600	10	1000

Tightening tip: It is essential that the installer follows the gasket manufacturer's installation guidelines when installing gaskets. Metallic gaskets, such as the spiral wound gaskets, usually have special installation instructions. One of these instructions includes a special procedure for tightening bolts/studs when installing new gaskets. The procedure recommends that the bolts/studs be torqued in four stages.

- Following the staggered tightening pattern, the bolts/studs should be torqued to 1/3 of the recommended tightening torque.
- Same as a, the bolts/studs should be torqued to 2/3 of the recommended tightening torque.
- Same as a, the bolts/studs should be torqued to the recommended torque valve shown in the above chart.
- Following the staggered tightening pattern the bolts/ studs torques should be checked for equilibrium since the tightening of one bolt/stud can relieve the stress on adjacent bolts/studs. If after following the gasket manufacturer's recommended tightening procedure a leak still occurs, the bolts/studs should be tightened in the torque increments shown until the leak stops. The staggered tightening pattern is still followed.

NOTE: When using spiral wound gaskets, both the head and the shell/tank gaskets must be spiral wound. You cannot mix one spiral wound and one compressed fiber gasket on a heat exchanger.

13. Refer to "OPERATION" steps 5 and 6 regarding bolt retightening after start-up.

14. Where frequent disassembly of the heat exchanger is encountered, the use of new bolting in conformance with dimension and ASTM specifications of the original design is recommended.

REPLACEMENT PARTS

When replacement parts are required, refer to part identified in the drawing of the proper unit. When ordering be sure full nameplate information is given including Nat'l. Bd. No. and/or Serial No.,

EXAMPLE:

One replacement tube bundle for: Serial No. XXXXX

Note: Gaskets are always furnished with replacement tube bundles and need not be ordered separately.

“DHT”,

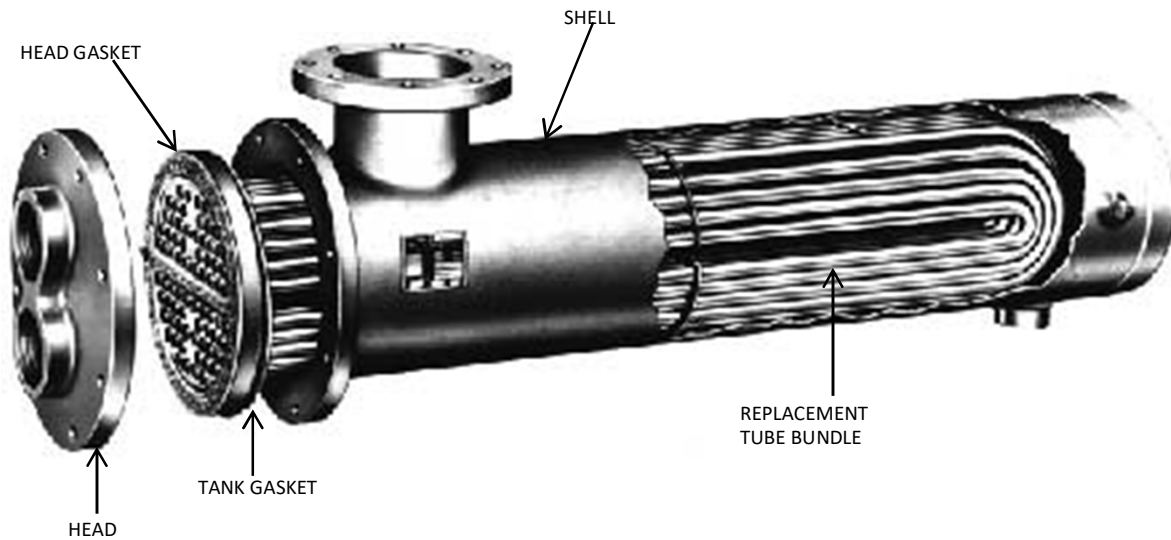

www.dhtnet.com