

MBA SERIES

ELECTRIC STEAM GENERATOR

- *Lbs/Hr Sat. Steam: 9 to 60*
- *KW Rating: 3 to 20*
- *ASME Rating 100 PSIG*
- *Operating PSIG Range 1-80 PSIG Max!*

Complete with Feed Water Strainer / Solenoid / Check Valve

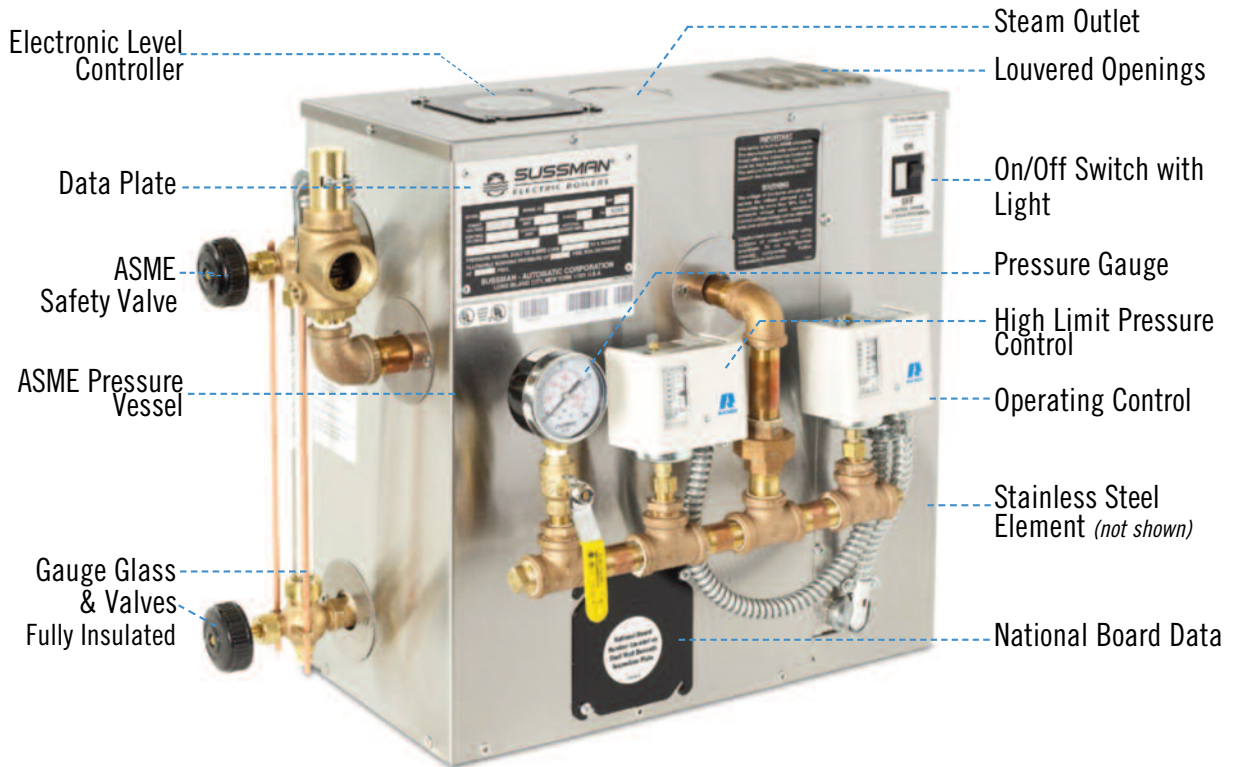

TYPICAL BOILER ARRANGEMENT



Built to ASME Code



Sussman MBA Packaged Electric Steam Generators

Small size, small capacity Sussman MBA Electric Steam Generators are perfect for industries that require efficient, high quality steam in laboratories, hospitals, computer rooms, pilot plants and for small intermittent, low-steam consuming loads.

These generators are perfect for standby operations in off seasons or when a larger boiler is shut down or unavailable. The automatic electronic controller meets all UL and ASME requirements. A main waterline pressure 10 psig greater than the operating pressure of the steam generator is required for automatic water feeding.

All MBA Steam Generators are factory tested and are ready to operate.

Sussman MBA Series Features:

- Safe and easy-to-use heat source – no on-site products of combustion.
- Easy and quick to install, they require only a water feed connection and electrical hook-up.
- Steam available at the flip of a switch
- Applications include: laboratory use, steam for small tanks, reactions and distillations, autoclaves, food products, jacketed vessels for processing waxes, paraffins, glues, resins & varnishes, and wood bending.
- UL and cUL Listed

STANDARD FEATURES

- LIQUID LEVEL / LWCO CONTROLLER**
 The electronic controller automatically maintains proper water level, and shuts off the generator when water supply in the boiler drops below a safe operating level.
- WATER LEVEL SIGHT GLASS**
 Allows constant observation of water level while boiler is in operation.
- ON-OFF SWITCH**
 Complete with pilot light, for switching on the generator.
- INTEGRAL ELECTRICAL CONTROL**
 Magnetic contactor energizes the element and is integrally mounted in the control unit.
- BLOWDOWN/DRAIN VALVE**
 Facilitates emptying the pressure vessel during blow-down/drain sequence.
- J-BOX** for motor/pump connection.
- LONG LIFE HEATING ELEMENTS**
 Industrial grade, heavy duty stainless steel heating elements equipped with one piece resistance welded terminations for added strength and safety.
- OPERATING PRESSURE CONTROL**
 Operates automatically to maintain steam pressure within generator.
- MANUAL RESET PRESSURE CONTROL**
 Provides high limit pressure cut-out with manual reset.
- STEAM SAFETY VALVE**
 ASME Code valve, automatically opens to reduce pressure should excessive steam cause pressure build-up.
- STEAM PRESSURE GAUGE**
 Allows visual observation of steam pressure over full range.
- ENERGY SAVING AND MINIMUM MAINTENANCE**
 Fully insulated pressure vessel minimizes heat loss and maximizes energy savings.
- EASY CONTROL MAINTENANCE**
 All controls and components are easily accessible; Fully-louvered openings avoid component heat build-up.
- RUGGED CONSTRUCTION**
 Performance is insured for all typical industrial applications.

MBA Electric Steam Generator

Component Identification Dimensional Information

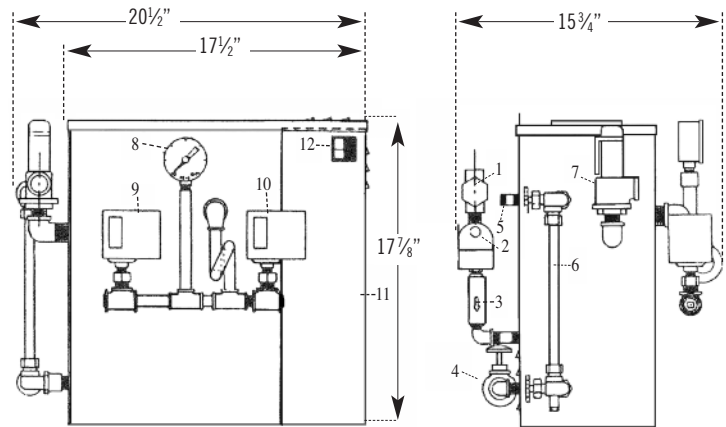

Symbol	Description
1	Strainer
2	Water Solenoid
3	Check Valve
4	Drain Valve
5	Steam Outlet
6	Gauge Glass Assembly
7	Safety Valve
8	Pressure Gauge
9	Hi-Limit Pressure Control
10	Operating Pressure Control
11	Access Panel
12	On/Off Switch

CODE REQUIREMENTS

- Pressure vessel rated at 100PSIG to ASME Section I, and National Board registered.
- UL and cUL listed, built to NEC.
- All units are physically identical and have a packed shipping weight of 125 lbs.
- Units are trimmed at 100PSIG as standard. 15PSIG trim also available.
- Incoming water line pressure must be 10 PSIG greater than generator operating pressure. If not, a motor/pump must be used. Specify Sussman MBA38002A high pressure water feed motor/pump system.
- When ordering specify Model No., KW, Volts/PH and motor/pump if required.
- Water Connection is 1/4 NPT. Steam outlet is 1/2 NPT.5

Model	KW	Volts	PH	Amps	PPH*
MBA3	3	120,208,240	1	25, 15, 13	9
MBA6	6	208,240,480	3	17, 15, 8	18
MBA9	9	208,240,480	3	25, 22, 11	27
MBA12	12	208,240,480	3	34, 29, 15	36
MBA18	18	208,240,480	3	50, 44, 22	54
MBA20	20	208,240,480	3	56, 49, 25	60

*Lbs./hr steam at 212°F with 50°F feedwater