

4

3

2

1

NOTES:

1. MATERIALS OF CONSTRUCTION

1. VESSEL AND PIPING: CARBON STEEL AND CAST IRON

2. JACKET: STAINLESS STEEL AND PAINTED STEEL

2. PRESSURE VESSEL BUILT IN ACCORDANCE WITH ASME SECTION IV AND CARRIES AN "H" STAMP

3. MAXIMUM ALLOWABLE WORKING PRESSURE UP TO 150PSI

4. BOILER IS UL LISTED TO STANDARD 834

5. FOR EWx630- EWx960 VOLTAGES 208, 240, 480 & 600

6. BACNET IP AND MSTP, MODBUS RS485, AND 4-20 mA REMOTE SET POINT STANDARD

7. REFER TO THE INSTALLATION AND OPERATION MANUAL FOR MORE INFORMATION

Center of Gravity		
X	Y	Z
0.49	18.41	-3.55

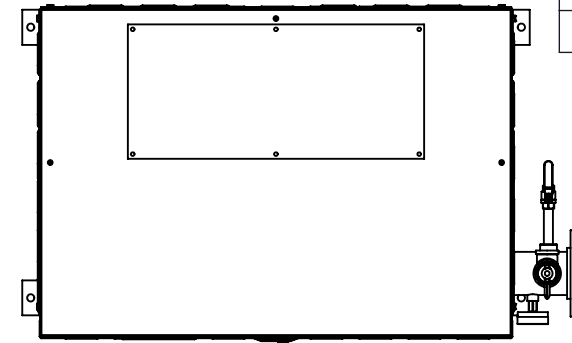

TOP

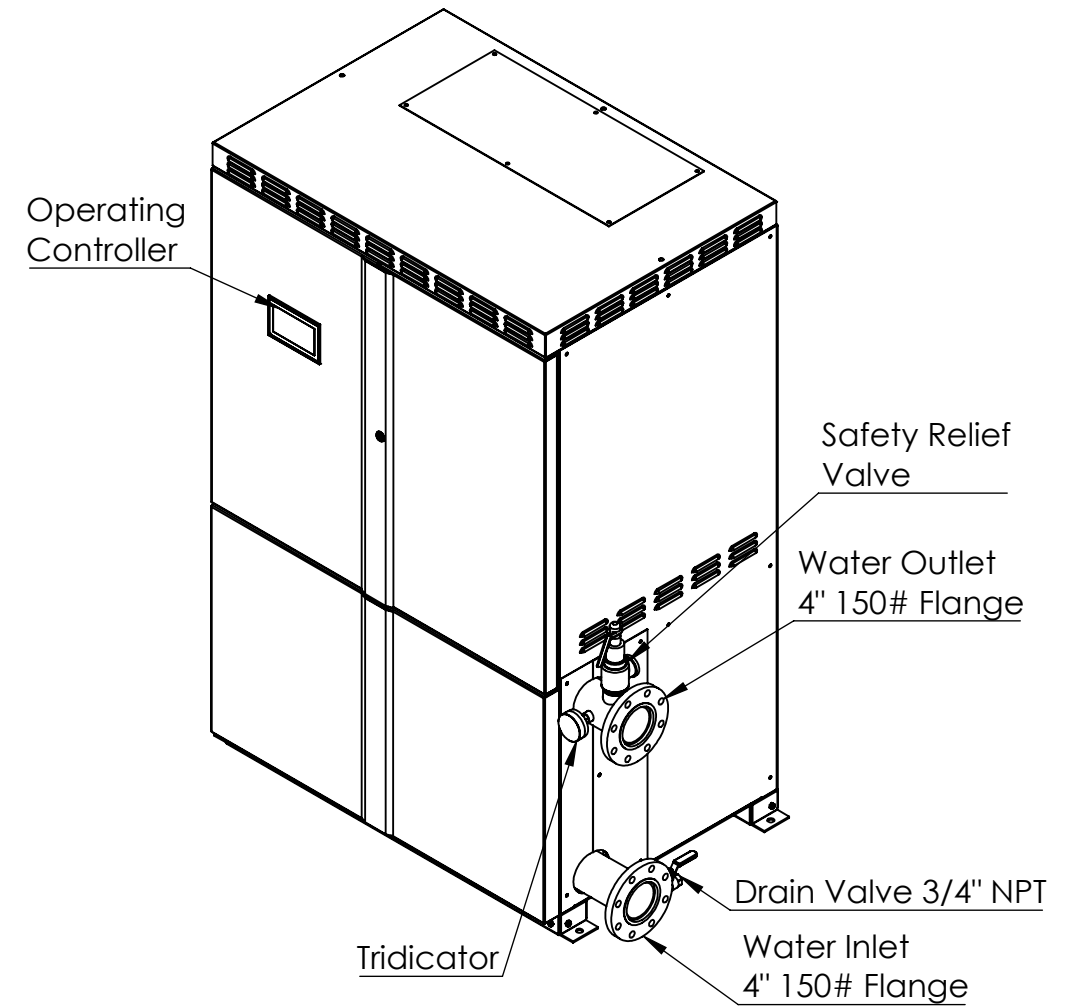

B

B

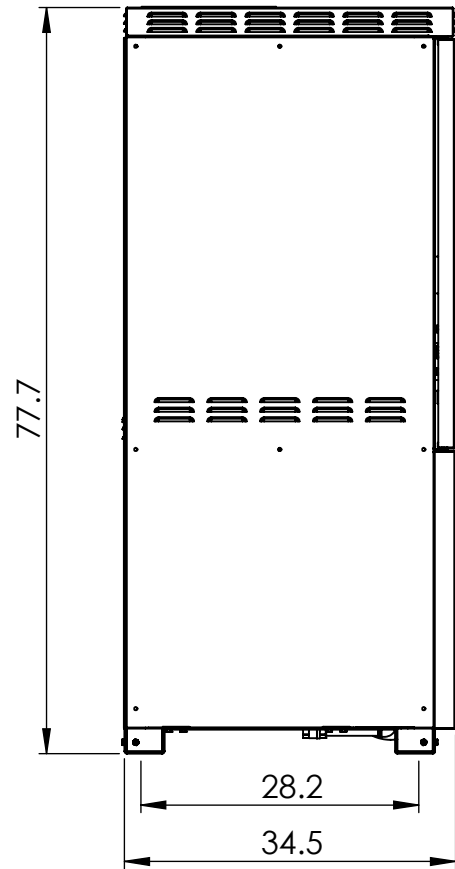

LEFT

Mounting Holes
4 Ø .75"

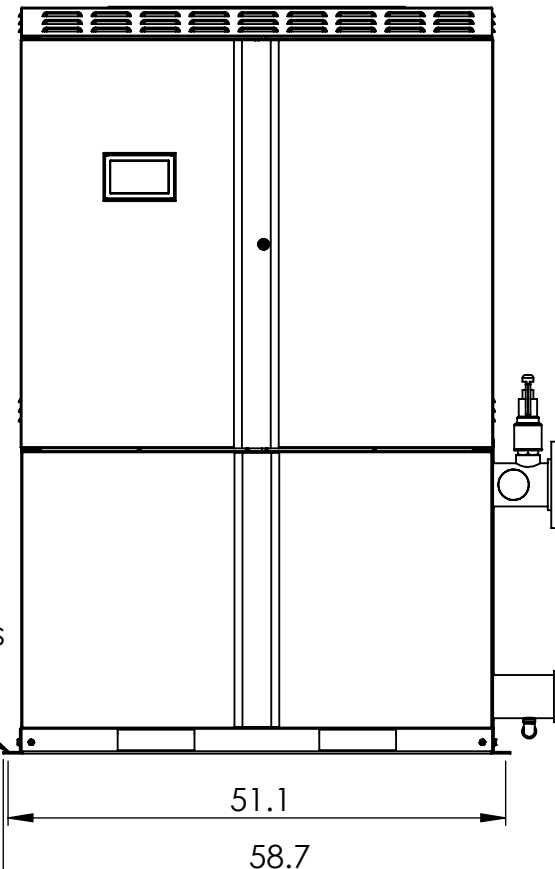

FRONT

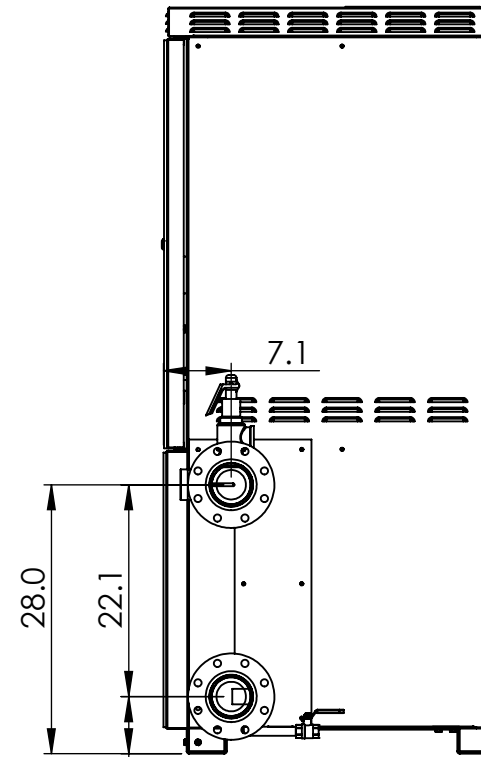

RIGHT

DIMENSIONS ARE SHOWN IN INCHES (CENTIMETERS)
 TOLERANCES ARE AS FOLLOWS UNLESS OTHERWISE SPECIFIED
 X.XX X.XXX X.XXXX ANGULAR FINISH
 ±.12 ±.031 ±.0156 ±1.0° 250

REMOVE AND DEBURR SHARP EDGES AND CORNERS
 ALL DIMENSIONS ARE AFTER FINISH OR PLATING
 REFERENCE DIMENSIONS ARE SHOWN IN PARENTHESES ()
 CRITICAL DIMENSIONS ARE SHOWN IN

THIS DRAWING AND/OR SPECIFICATIONS ARE THE PROPERTY OF DIVERSIFIED HEAT TRANSFER INC. THIS CONFIDENTIAL AND PROPRIETARY INFORMATION SHALL NOT BE USED, COPIED OR REPRODUCED IN ANY MEANS AS THE BASIS FOR MANUFACTURE OR SALE OF APPARATUS WITHOUT WRITTEN AUTHORIZATION FROM OWNER.



439 MAIN RD. TOWACO NJ 07082
 PHONE: (800) 221-1522 FAX: (718) 386-7809

TITLE EWx630-EWx960 ELECTRIC WATER BOILERS

A

A

A		FOR RELEASE	JH	1/15/25
REV	ECN	REVISION DESCRIPTION	NAME	DATE

THIRD ANGLE PROJECTION	DWG. SCALE	MATERIAL SPEC:	NAME	DATE	DWG#	REV
	1:20		JH	10/24/24	EWx630-EWx960	A
			CHECKED BY		SHEET 1 OF 2	

4

3

2

1

4

3

2

1

NOTES:
 1. SERVICE CLEARANCES TO BE IN CONFORMANCE TO NEC REQUIREMENTS. ALLOW A MINIMUM OF 36" CLEARANCE IN FRONT OF DOORS FOR SERVICING OF HEATING ELEMENTS. RECOMMENDED 24" CLEARANCE FOR OTHER SIDES OF BOILER FOR SERVICING.
 2. MINIMUM 1" CLEARANCE TO ALL COMBUSTIBLE MATERIALS

Service Clearance Requirements

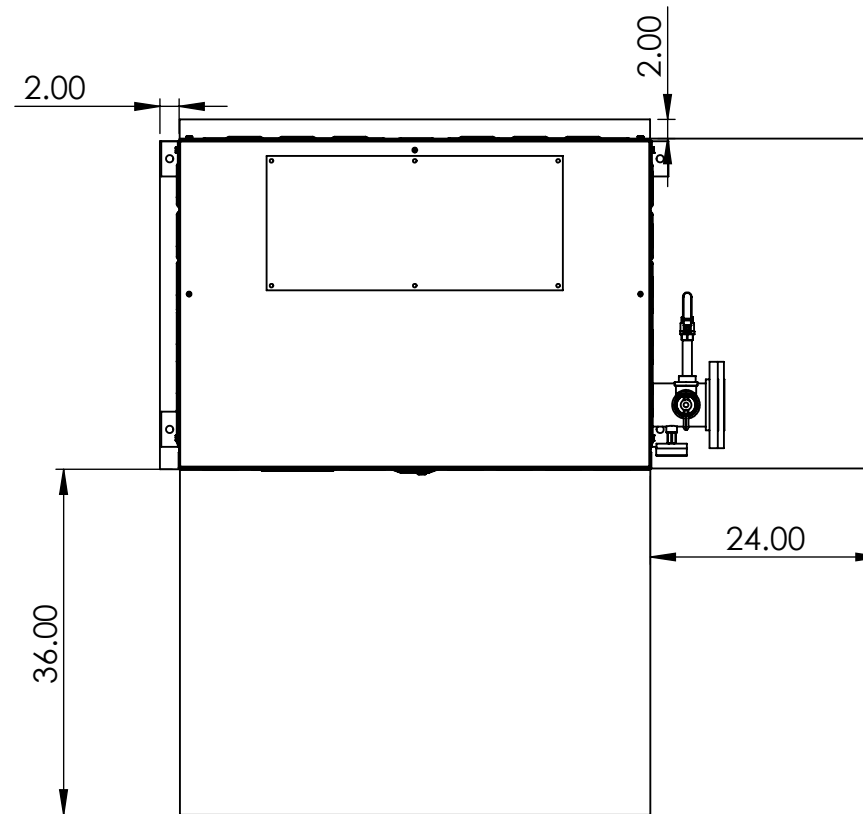

DIMENSIONS ARE SHOWN IN INCHES (CENTIMETERS)
 TOLERANCES ARE AS FOLLOWS UNLESS OTHERWISE SPECIFIED
 X.XX X.XXX X.XXXX ANGULAR FINISH
 ±.12 ±.031 ±.0156 ±1.0° 250
 REMOVE AND DEBURR SHARP EDGES AND CORNERS
 ALL DIMENSIONS ARE AFTER FINISH OR PLATING
 REFERENCE DIMENSIONS ARE SHOWN IN PARENTHESES ()
 CRITICAL DIMENSIONS ARE SHOWN IN

THIS DRAWING AND/OR SPECIFICATIONS ARE THE PROPERTY OF DIVERSIFIED HEAT TRANSFER INC. THIS CONFIDENTIAL AND PROPRIETARY INFORMATION SHALL NOT BE USED, COPIED OR REPRODUCED IN ANY MEANS AS THE BASIS FOR MANUFACTURE OR SALE OF APPARATUS WITHOUT WRITTEN AUTHORIZATION FROM OWNER.



439 MAIN RD. TOWACO NJ 07082
 PHONE: (800) 221-1522 FAX: (718) 386-7809

TITLE EWx630-EWx960 ELECTRIC WATER BOILERS

A		FOR RELEASE	JH	1/15/25
REV	ECN	REVISION DESCRIPTION	NAME	DATE

THIRD ANGLE PROJECTION	DWG. SCALE	MATERIAL SPEC:	NAME	DATE	DWG#	REV
	1:20		JH	10/24/24	EWx630-EWx960	A
			CHECKED BY		SHEET 2 OF 2	

4

3

2

1