

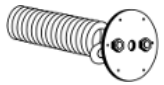









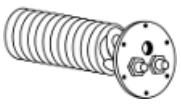

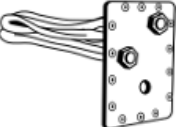
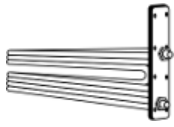

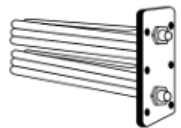

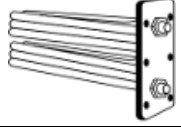

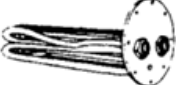
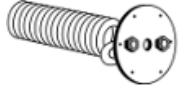

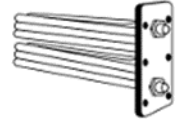
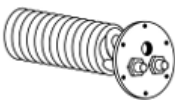
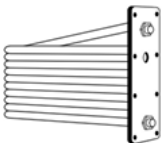
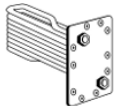
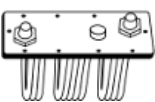
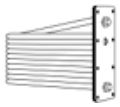
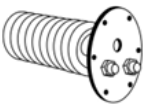
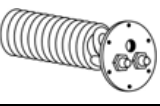
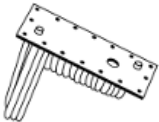

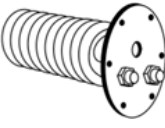
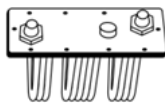
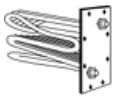

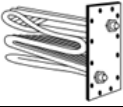
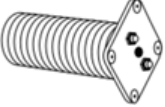
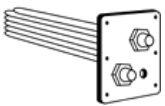
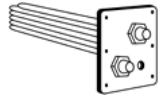
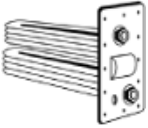

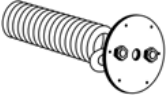

BOILER SERIES	HEATER NUMBER	RES	TRADE PRICE \$
AMERICAN			
	ARCOLEADER 8" DIA.-6 BH	700-5	5 629
		700-6	6 712
		700-8	8 891
		700-10	10 1053
	ARCOLINER-N.B. 4" IPS SCREW TYPE	603-4	4 548
		604-5	5 633
		605-6	6 748
	ARCOLINER-N.B. WIDE BACK 6½ X 17 ¾ - 14 BH	589-5	5 660
		589-6	6 729
		589-8	8 1030
		589-10	10 1373
	A-3, FRA-3, APT, PFA-3, G-2, G-40 7½ DIA. - 6 BH	A3-5	5 536
		A3-6	6 603
		A3-8	8 807
		A3-10	10 999
		A3-12	12 1380
		A3-15	15 1656
	A-5 FRA-5 4½ X 14½-8 BH *Water Only	A5-4	4 595
		A5-5	5 637
		A5-6	6 729
		A5-7	7 834
		*A5-8	8 1015
	EXBROOK 10 X 13½ - 14 BH	593-6	6 934
		593-8	8 1105
		593-10	10 1263
		593-12	12 1489
		593-15	15 1863
	5 ½ X 12-8 BH *Water Only	G10-5	5 663
		G10-6	6 834
		G10-8	8 949
	OAKMONT 8-11 CAST IRON SHELL 8 X 19 ½ - 17 BH *STEEL SHELL	585-5	5 1141
		585-6	6 1177
		585-8	8 1451
		585-10	10 1787
		585-12	12 2077
		*585-15	15 2717
	PFA-5 5 ¾ X 11-6 BH	PFA-5	5 660
		PFA-6	6 734
		PFA-8	8 921
		PFA-10	10 1175
		PFA-12	12 1382

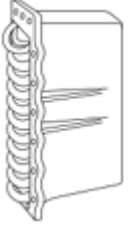
BOILER SERIES	HEATER NUMBER	RES	TRADE PRICE \$
AMERICAN			
	SEVERN 7 ½ X 13½ - 12BH *Extended Shell	590-5	5 958
		*590-6	6 1225
		*590-8	8 1287
		*590-10	10 1422
BURNHAM			
	FIESTA, FIESTA II, LIBERTY 8 ½ X 12 ½ -10BH	FT-5	5 671
		FT-6	6 851
		FT-8	8 1039
	JUBILEE 100 HOLIDAY 60-61-62 PM-PB-PP HOLIDAY 6-72 GAS 7½" - 6BH Water Boilers	100-5	5 614
		100-6	6 637
		100-8	8 922
		100-10	10 1074
		100-12	12 1291
		100-15	15 1621
	HOLIDAY 70-80-81 PACEKING-FR SPECIFY STEAM OR WATER 10½" DIA.-8 BH	PK-5	5 763
		PK-6	6 834
		PK-8	8 1043
		PK-10	10 1245
		PK-12	12 1489
		PK-15	15 1866
		PK-18	18 2113
		PK-20	20 2537
		PK-25	25 3088
		JUBILEE 200-FR Water Boilers 8" DIA.-6BH	BJW-5
		BJW-6	6 648
		BJW-8	8 933
		BJW-10	10 1196
	JUBILEE 200-FR Steam Boilers 8" DIA.-6 BH	BJS-4	4 651
		BJS-5	5 648
		BJS-6	6 933
		BJS-8	8 1196
	PACEMAKER HOL. 60-61 Steam Boilers 7½ DIA.-6 BH	100S-4	4 651
		100S-5	5 714
		100S-6	6 822
	PF-5 5 ¾ X 11-6 BH	PF-5	5 658
		PF-6	6 734
		PF-8	8 921
		PF-10	10 1174
	PF-12	12 1382	

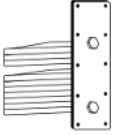
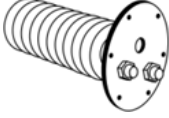
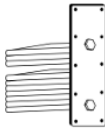
BOILER SERIES		HEATER NUMBER	RES	TRADE PRICE \$	
BURNHAM					
	V8 WATER ONLY V3 WATER OR STEAM V7, VP, PF3 PATRIOT - FREEDOM 6 MEGASTEAM 7 ½ DIA.-6 BH	V8W-5	5	497	
		V8W-6	6	539	
		V8W-8	8	763	
		V8W-10	10	946	
		V8W-12	12	1304	
		V8W-15	15	1567	
	V8 STEAM V7 STEAM V1 STEAM OR WATER 5 X 12¼ - 8 BH *V9 Must specify	V8S-5	5	537	
		V8S-6	6	592	
		V8S-8	8	821	
		V8S-10	10	1090	
		*V8S-12	12	1282	
		*V8S-15	15	1556	
		V11 6 3/16 x 12 3/8-8BH	V11-8	8	872
			V11-10	10	1121
V11-12	12		1307		
	YELLOW JACKET 7 X 9¼-10 BH	YJ-5	5	672	
		YJ-6	6	851	
		YJ-8	8	1039	
CROWN					
	CDB BON-AIR EMPIRE ULTIMATE 6¼ X 11 ¼-10BH	CDB-5	5	562	
		CDB-6	6	604	
		CDB-8	8	850	
	KINGSTON 5 X 12¼ - 8 BH	CK-5	5	533	
		CK-6	6	602	
		CK-8	8	821	
	MONTEGO 8" DIA.-6 BH	CDM-5	5	610	
		CDM-6	6	639	
		CDM-8	8	901	
		CDM-10	10	999	
	TOBAGO CAYMAN BAHAMA 7 ½ DIA.-6 BH	TW-5	5	506	
		TW-6	6	570	
		TW-8	8	763	
DELCO FLAT PLATE TYPE					
	DB 3-4-5 8 ¾ X 20-16 BH *SHELL TYPE	DP-6	6	805	
		DP-8	8	1129	
		*DP-10	10	1972	
		*DP-12	12	2079	
DUNKIRK					
	13 STEAM 2D-GAS 6¼ X 17-14 BH	13S-5	5	643	
		13S-6	6	683	
		13S-8	8	940	

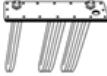
BOILER SERIES		HEATER NUMBER	RES	TRADE PRICE \$
DUNKIRK				
	LEXINGTON SUPER-13 8" DIA.-6 BH	1342-4	4	573
		1342-5	5	597
		1342-6	6	665
		1342-8	8	959
		1342-10	10	1185
	ULTIMATE 6¼ X 11¼ - 10BH	ULT-5	5	562
		ULT-6	6	604
		ULT-8	8	650
		ULT-10	10	946
	EMPIRE STEAM 6½ X 10½-8 BH	ESC-5	5	570
		ESC-6	6	625
		ESC-8	8	914
DUNKIRK-DELCO-FEDERAL-PARAGON-PIETRO-C.I. BLR				
	DUNKIRK 13W- 15W-S DELCO 525- 1260 FED.OXFORD JUPITER 2¾" - 5" - 7" *SPECIFY CONN. CTRS.	PN-4	4	615
		PN-5	5	640
		PN-6	6	669
		PN-8	8	1020
HART & CROUSE- BRYANT				
	COMPACT 230-231-234 5¼ X 12-12 BH	HC-4	4	632
		HC-5	5	709
		HC-6	6	772
H.B. SMITH				
	PAC 12-FD SERIES 8 WATER 7¼ X 7¼-4 BH	8W-4	4	497
		8W-5	5	576
		8W-6	6	680
		8W-8	8	876
		8W-10	10	1054
	SERIES 8 STEAM 4 OR 5 GPM ONLY 7 ¼ X 7 ¼-4 BH	8S-4	4	492
		8S-5	5	520
	28 STEAM BLRS 7½ X 8½-6 BH	28-6	6	596
		28-8	8	882
		28-10	10	1031
		28-12	12	1137
		28-15	15	1456
	18-19 SERIES 5¼ X 12-6BH	ST19-6	6	596
		ST19-8	8	882
		ST19-10	10	1031
		ST19-12	12	1137
		ST19-15	15	1504

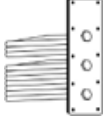
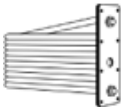
BOILER SERIES		HEATER NUMBER	RES	TRADE PRICE \$
H.B. SMITH				
	20-25-200-250 201-251 2000 A-L-ABC 2500 A-L 6½ X 12-12 BH	2025-6	6	785
		2025-8	8	1129
		2025-10	10	1302
		2025-12	12	1477
		2025-15	15	1859
		2025-20	20	2484
		2025-25	25	2835
	1100-1500 FLANGE TYPE 6½ X 16-14 BH	1115-5	5	738
		1115-6	6	797
		1115-8	8	1050
		1115-10	10	1221
	CENTURY GAS III 100-150-300-400 SCREW TYPE 4" IPS	4-4	4	548
		4-5	5	633
		4-6	6	747
		4-8	8	990
		4-10	10	1161
		4-12	12	1350
		4-15	15	1478
	OB-14 BB-14 12" DIA.-6 BH	14-5	5	660
		14-6	6	685
		14-8	8	956
		14-10	10	1204
HYDROTHERM				
	AQUARIUS 7½ DIA.-6 BH	AQ-5	5	616
		AQ-6	6	663
		AQ-8	8	1013
	OS-SOT 4¾ X 10-8 BH	OS-5	5	615
		OS-6	6	663
		OS-8	8	1013
	VO-WT-V.G. 6" DIA.-6 BH	VO-5	5	595
		VO-6	6	643
	VOA-STEAM VGA 5¾ X 11 ¼-10BH	VOA-5	5	615
		VOA-6	6	671
		VOA-8	8	983
NATIONAL-U.S.-CRANE				
	NAT.-U.S. 2-9-16-16C-20 25-28-32 CAST IRON SHELL 8¾ X 20-16 BH * Steel Shell	921-5	5	1142
		921-6	6	1177
		921-8	8	1451
		921-10	10	1787
		921-12	12	2077
		*921-15	15	2717
		*921-20	20	3299

BOILER SERIES		HEATER NUMBER	RES	TRADE PRICE \$
NATIONAL-U.S.-CRANE				
	NAT.-U.S. SUNRAY IV-19 CRANE-5 THATCHER-OC 6½ X 17½-10BH	19-5	5	642
		19-6	6	704
		19-8	8	1050
		19-10	10	1245
	NAT.-U.S. 17-18 70-101-109-209 300 CRANE-2-8-11-12 202-300-302 Thatcher-G-OP 7¾ DIA.-6 BH	104-4	4	561
		104-5	5	590
		104-6	6	640
		104-8	8	894
		104-10	10	1177
		104-12	12	1312
	NAT.-U.S. 109SS-SW 200SS-SW CRANE-202SS-SW 7¾ X 15¾-12 BH	109SS-4	4	621
		109SS-5	5	761
		109SS-6	6	797
		109SS-8	8	1077
	CRANE 15-26 6" DIA.-4 BH	15-4	4	588
		15-5	5	618
		15-6	6	703
		15-8	8	961
	NAT.-U.S. 12-12W Flange type 7 x 22½-16BH	12-5	5	763
		12-6	6	834
		12-8	8	1103
	NAT.-U.S. SUNRAY 1-3-46 6½ X 16¾-13 BH	119-5	5	696
		119-6	6	766
		119-8	8	1024
	CRANE 14-20 7½ X 13½-12 BH *Specify extended shell	1420-5	5	822
		1420-6	6	943
		*1420-8	8	1225
		*1420-10	10	1421
	CRANE 16 5 ½ x 12-10 BH	16-5	5	822
		16-6	6	943
		16-8	8	1225
		16-10	10	1421
	73 70SS-SW 5 X 12½-8 BH	73-5	5	636
		73-6	6	697
		73-8	8	894
	NAT.-U.S. CRANE 80 11¾" DIA.-8 BH	80-6	6	921
		80-8	8	1043
		80-10	10	1273
		80-12	12	1500
		80-15	15	1907
		80-20	20	2236
		80-25	25	2794

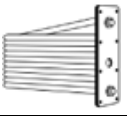
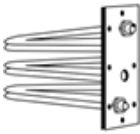
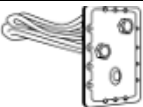
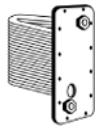
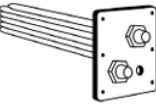
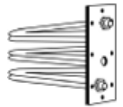
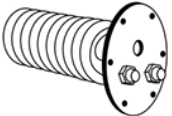
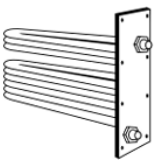
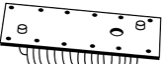
BOILER SERIES		HEATER NUMBER	RES	TRADE PRICE \$		
NEW YORKER						
	NEW YORKER CLW-WATER	CL-5	5	535		
	CLS-STEAM	CL-6	6	593		
	5 X 12½ - 8 BH	CL-8	8	821		
PEERLESS - STEAM						
	ECT-STEAM 5 3/16 X 9 7/8-8 BH *SHELL INCLUDED	ECT-5	5	511		
		ECT-6	6	588		
		ECT-8	8	864		
		ECT-10	10	1066		
		*ECT-12	12	2682		
		*ECT-15	15	2983		
	HEO-STEAM OR WATER 7 ¼ X 11-8 BH	HEO-5	5	569		
		HEO-6	6	629		
		HEO-8	8	878		
	JO-JOT-2-2T- STEAM 6 ¼ X 14¼-12 BH	JOT-5	5	550		
		JOT-6	6	622		
		JOT-8	8	878		
		JOT-10	10	1076		
	TC SERIES STEAM OR WATER 7½ X 8½-6BH	TC-6	6	596		
		TC-8	8	887		
		TC-10	10	1031		
		TC-12	12	1137		
		TC-15	15	1476		
	WBV-STEAM 5 9/16 X 9 7/8-8 BH	WBV-5	5	511		
		WBV-6	6	589		
		WBV-8	8	864		
PEERLESS - WATER						
	JO-JOT-FD-LC 2-2T 7-7PF 60-61-81 WBV WATER ECT-STEAM 8" DIA.-6 BH	PR-5	5	508		
		PR-6	6	551		
		PR-8	8	817		
		PR-10	10	963		
		PR-12	12	1062		
		PR-15	15	1262		
		PR-20	20	1610		
		RICHMOND-RHEEM-RUDD				
	RHEEM-G-O-PO RICHMOND-RWA H-WFD-R-RW-PR 5 ¼ x 13 ½ -8 BH	RR-5	5	552		
		RR-6	6	671		
		RR-8	8	983		
		RO-5	5	625		
	RICHMOND-RWA H-WFD-R-RW-PR 5 ¼ x 15 ½ -10 BH	RO-6	6	671		
		RO-8	8	983		
		SLANT FIN				
			GALAXY MALIBU 8¾ X 15½-12BH	SF-5	5	563
SF-6	6			636		
SF-8	8			975		
SF-10	10			1154		

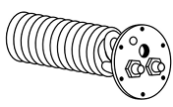
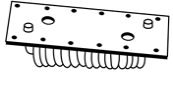
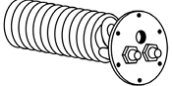
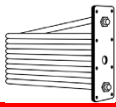
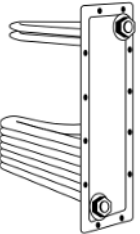
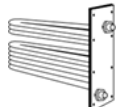
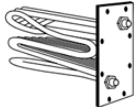
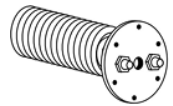
BOILER SERIES		HEATER NUMBER	RES	TRADE PRICE \$	
SLANT FIN					
	LIBERTY WATER INTREPID 7 ½" DIA.6 BH	LW-4	4	571	
		LW-5	5	543	
		LW-6	6	621	
		LW-8	8	917	
		LW-10	10	1080	
	LIBERTY STEAM BOILERS INTREPID 8 1/8 X 15 15/16-12 BH	LS-5	5	611	
		LS-6	6	631	
		LS-8	8	967	
		LS-10	10	1147	
	VANTAGE II FUTURA 7 ½" DIA.-6 BH	FUT-5	5	622	
		FUT-6	6	650	
		FUT-8	8	975	
	78 5 X 12½-8 BH	78-5	5	637	
		78-6	6	697	
		78-8	8	1100	
THATCHER					
	015 THRU 020 6 X 20¼ -12 BH	T-5	5	797	
		T-6	6	822	
		T-8	8	1114	
		T-10	10	1299	
	56 SERIES 7¼ X 19-14 BH	56-5	5	797	
		56-6	6	821	
		56-8	8	1114	
	525 SERIES 6¼ X 14¼-12BH	525-5	5	797	
		525-6	6	821	
		525-8	8	1114	
	GOLDEN OILMASTER	WATER BOILERS SAME AS BURNHAM BJW			
		STEAM BOILERS SAME AS BURNHAM BJS			
T.F. GAS	SAME AS BURNHAM HOLIDAY 70-80				
UTICA-RADIATOR					
	STARFIRE ACE-OU 5¼ X 13½-8 BH	UST-5	5	609	
		UST-6	6	665	
		UST-8	8	974	
	STARFIRE II, III-STEAM B-C OIL-GAS, POBT 6¼ X 10½-8 BH	STS-5	5	559	
		STS-6	6	610	
		STS-8	8	913	
	STARFIRE II, III-WATER 7¼ DIA.-6 BH	STW-4	4	504	
		STW-5	5	511	
		STW-6	6	585	
		STW-8	8	914	

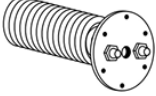
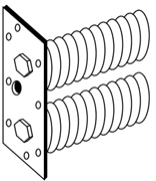
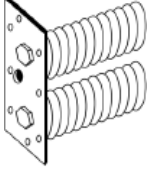
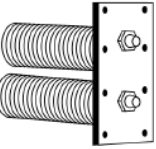
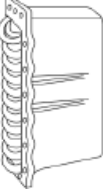
BOILER SERIES	HEATER NUMBER	RES	TRADE PRICE \$	
WEIL-MCLAIN-WILLIAMSON-THERMFLO				
	65-66-68-EG-68V 42-62 WATER BOILERS 7 1/4 DIA.-6 BH	68W-5	5	470
		68W-6	6	510
		68W-8	8	775
		68W-10	10	1021
		68W-12	12	1286
	GOLD OIL OWT WATER BOILER 7 1/4 DIA.-6 BH	GOW-5	5	474
		GOW-6	6	553
		GOW-8	8	775
		GOW-10	10	1021
		GOW-12	12	1286
	GOLD-65-66-68-EG OSB/T STEAM BOILERS 6 X 10-8 BH	GOS-5	5	496
		GOS-6	6	559
		GOS-8	8	842
		GOS-10	10	970
	76-86-88 6 X 10-8 BH * 86-88-ONLY	7686-6	6	570
		7686-8	8	823
		7686-10	10	941
		7686-12	12	1085
		7686-15	15	1250
		*7686-20	20	1720
	80 SERIES & 785 1/4 X 10 1/8-8 BH	WM80-6	6	570
		WM80-8	8	842
		WM80-10	10	942
		WM80-12	12	1085
		WM80-15	15	1256
		WM80-20	20	1720
MULTIPLE HEATERS CAN BE USED WITH 76-86-88-78				
WEIL-MCLAIN				
	LG STEAM 4 X 11 1/2-8 BH	LGS-5	5	668
		LGS-6	6	705
		LGS-8	8	953
	E STEAM BOILERS E-5 1/2 X 10 1/4-8 BH	ES-5	5	595
		ES-6	6	637
		ES-8	8	942
	62 STEAM 5 1/4 X 8 3/4-6 BH	62S-5	5	595
		62S-6	6	636
		62S-8	8	943
	57-77 78-B5 CAST IRON SHELL 8 1/4 X 20-16 BH *Steel Shell	7735-5	5	1141
		7735-6	6	1171
		7735-8	8	1451
		7735-10	10	1787
		7735-12	12	2077
		*7735-15	15	2717
		*7735-20	20	3299

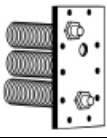
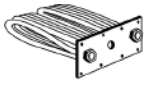
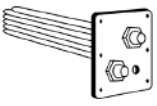
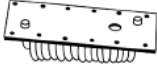
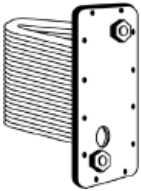
BOILER SERIES	HEATER NUMBER	RES	TRADE PRICE \$	
WEIL-MCLAIN				
	72-73 6 1/4 X 10 1/4 -10 BH	7273-6	6	660
		7273-8	8	892
		7273-10	10	997
		7273-12	12	1093
		7273-15	15	1393
	82-84 6 X 14-10 BH	8284-6	6	660
		8284-8	8	892
		8284-10	10	997
		8284-12	12	1093
		8284-15	15	1393
	CGT-GAS 5 1/2 X 13 1/2-10BH	CGT-8	8	1017
	OB15 5 1/4 X 11 3/4-8 BH	OB15-5	5	642
		OB15-6	6	683
		OB15-8	8	958
	OB15 5 1/4 X 11 3/4-8 BH	OB18-5	5	642
		OB18-6	6	683
		OB18-8	8	958
	92-94-K 5 1/4 X 7-6 BH	92-8	8	925
		92-10	10	963
		92-12	12	1234
		92-15	15	1408
		92-20	20	1877
	H-GAS 8 1/2 X 20-16 BH *Extended Shell	H-5	5	897
		H-6	6	921
		H-8	8	1409
		*H-10	10	1972
WILLIAMS-WINKLER-STEWART-WARNER				
	OILOMATIC-C CI-CIC-CIR 6 1/4 X 14 1/4-12 BH	WW-5	5	643
		WW-6	6	728
		WW-8	8	892
		WW-10	10	1074
		WO-5	5	643
	OILOMATIC-C CI-CIC-CIR 6 1/4 X 14 1/4-14 BH	WO-6	6	728
		WO-8	8	892
		WO-10	10	1074

OTHER POPULAR MISCELLANEOUS COILS

REPLACEMENT CAST IRON & STEEL BOILER TANKLESS PLEASE SPECIFY BOILER MAKE, SERIES & NUMBER AND PLATE DESCRIPTION

	RES	LIST PRICE
AXE-AND	4	597
BLUERAY	5	602
BRYANT	6	682
BURNHAM RSA, RSM	7	856
CROWN	8	999
COLUMBIA	10	1199
ENERJET	12	1578
KERR	15	1737
NEW YORKER	16	LARGER SIZES AVAILABLE CALL FOR PRICING
PEERLESS	18	
REPCO	20	
THERMODYNAMICS	24	
OS,NS	25	
UTICA	27	
VALIANT	30	
	35	
	40	

PLEASE CALL FOR ANY COILS NOT LISTED ABOVE

CAPACITY RATING BASED ON TEMPERATURE RISE FROM 40° TO 140°, WITH BOILER WATER 200°. FIRING RATE TO BE SUITABLE FOR MAINTAINING 200° BOILER WATER- ON ALL UNITS

DHT RESIDENTIAL PRODUCTS

- TX Series Indirect Water Heater
- Techtanium Indirect Water Heater
- Flanged Duct Coils
- Cased Hydronic Coils (AHCC)
- Evaporator Coils
- Brazed Plate Heat Exchanger
- E-ZEE Flow Heat Exchanger

HVAC Coils

- Water Coils: Chilled Water, Hot Water
- Standard Steam Coils
- Steam Distributing Coils (Non-Freeze Steam Coils)
- Condenser Coils
- Evaporator Coils

Lindy Commercial Coils

DHT COMMERCIAL/ INDUSTRIAL PRODUCTS

- Indirect Water Heaters
- ST Series Semi-Instantaneous Water Heaters
- SP Series Superplate Water Heaters
- STP Series- Tank and Plate Storage Water Heater
- SS Series: Unfired Steam Generators

DHT SUSSMAN ELECTRIC BOILERS

Electric Hot Water Boiler

- EW Series Electric Hot Water Boiler
- SVW Vertical Hot Water Boilers

Electric Steam Boiler

- ES - Electric Steam Boiler
- MBA-Electric Steam Generator
- SSB - Stainless Steel Electric Steam Boiler
- SVS - Electric Steam Boiler

Heat Exchangers

- Shell & Tube Heat Exchangers
- Plate and Frame Heat Exchangers
- Brazed Plate Heat Exchanger
- Tube Bundles